

C400F-NMNM-2M



CNT-400-FR CNT® Jumper with interface types N Male and N Male, 2 m

Product Classification

Product Type	Braided cable assembly
Product Brand	CNT®
Product Series	CNT-400

General Specifications

Body Style, Connector A	Straight
Body Style, Connector B	Straight
Cable Family	CNT-400
Interface, Connector A	N Male
Interface, Connector B	N Male
Specification Sheet Revision Level	A

Dimensions

Length	2 m 6.562 ft
Nominal Size	0.400 in

VSWR/Return Loss

Frequency Band	VSWR	Return Loss (dB)
700–2000 MHz	1.222	20
2000–3000 MHz	1.288	18

Jumper Assembly Sample Label

C400F-NMNM-2M



Included Products

- 400APNM-C – Type N Male for CNT-400 braided cable
- 400BPNM-C – Type N Male for CNT-400 braided cable
- CNT-400-FR – CNT-400-FR, CNT® 50 Ohm Braided Coaxial Cable, black non-halogenated, fire retardant polyolefin jacket, Dca s2 d2 Compliant

400APNM-C

Type N Male for CNT-400 braided cable

Product Classification

Product Type	Braided cable connector
Product Brand	CNT®

General Specifications

Body Style	Straight
Inner Contact Attachment Method	Captivated
Inner Contact Plating	Gold
Interface	N Male
Outer Contact Attachment Method	Clamp
Outer Contact Plating	Trimetal

Dimensions

Width	20.25 mm 0.797 in
Length	38.22 mm 1.505 in
Diameter	20.25 mm 0.797 in
Nominal Size	0.405 in

Outline Drawing

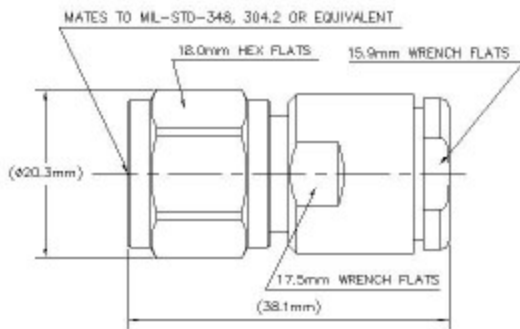

Electrical Specifications

Insertion Loss, typical	0.05 dB
Cable Impedance	50 ohm

400APNM-C

Connector Impedance	50 ohm
dc Test Voltage	2500 V
Inner Contact Resistance, maximum	1 mOhm
Insulation Resistance, minimum	5000 MOhm
Operating Frequency Band	0 – 6000 MHz
Outer Contact Resistance, maximum	0.25 mOhm
Peak Power, maximum	10 kW
RF Operating Voltage, maximum (vrms)	707 V

VSWR/Return Loss

Frequency Band	VSWR	Return Loss (dB)
0–3000 MHz	1.046	32.96
3000–6000 MHz	1.18	22

Mechanical Specifications

Connector Retention Tensile Force	330 N 74.187 lbf
Connector Retention Torque	0.56 N-m 4.956 in lb
Coupling Nut Proof Torque	1.7 N-m 15.046 in lb
Coupling Nut Proof Torque Method	IEC 61169-16:9.3.6
Coupling Nut Retention Force	450 N 101.164 lbf
Coupling Nut Retention Force Method	IEC 61169-16:9.3.11
Interface Durability	500 cycles
Interface Durability Method	IEC 61169-16:9.5
Mechanical Shock Test Method	IEC 60068-2-27

Environmental Specifications

Operating Temperature	-40 °C to +85 °C (-40 °F to +185 °F)
Storage Temperature	-65 °C to +125 °C (-85 °F to +257 °F)
Attenuation, Ambient Temperature	20 °C 68 °F
Average Power, Ambient Temperature	40 °C 104 °F
Average Power, Inner Conductor Temperature	100 °C 212 °F
Climatic Sequence Test Method	IEC 60068-1
Corrosion Test Method	IEC 60068-2-11

400APNM-C

Damp Heat Steady State Test Method	IEC 60068-2-3
Immersion Depth	1 m
Immersion Test Mating	Mated
Immersion Test Method	IEC 60529:2001, IP68
Thermal Shock Test Method	IEC 60068-2-14
Vibration Test Method	IEC 60068-2-6

Packaging and Weights

Weight, net 47.08 g | 0.104 lb

Regulatory Compliance/Certifications

Agency	Classification
ISO 9001:2015	Designed, manufactured and/or distributed under this quality management system
REACH-SVHC	Compliant as per SVHC revision on www.andrew.com/ProductCompliance
ROHS	Compliant
UK-ROHS	Compliant

* Footnotes

Insertion Loss, typical	0.05√freq (GHz) (not applicable for elliptical waveguide)
Immersion Depth	Immersion at specified depth for 24 hours

400BPNM-C



Type N Male for CNT-400 braided cable

Product Classification

Product Type	Braided cable connector
Product Brand	CNT® ConQuest®

General Specifications

Body Style	Straight
Inner Contact Attachment Method	Captivated
Inner Contact Plating	Silver
Interface	N Male
Outer Contact Attachment Method	Clamp
Outer Contact Plating	Trimetal

Dimensions

Width	20.25 mm 0.797 in
Length	35.48 mm 1.397 in
Diameter	20.25 mm 0.797 in
Nominal Size	0.405 in

Outline Drawing

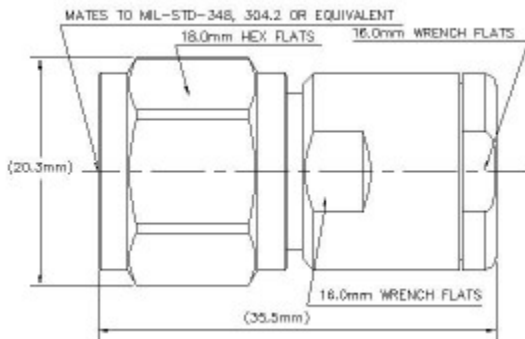

400BPNM-C

Electrical Specifications

Insertion Loss, typical	0.05 dB
Cable Impedance	50 ohm
Connector Impedance	50 ohm
dc Test Voltage	2500 V
Inner Contact Resistance, maximum	1 mOhm
Insulation Resistance, minimum	5000 MOhm
Operating Frequency Band	0 – 6000 MHz
Outer Contact Resistance, maximum	0.25 mOhm
Peak Power, maximum	10 kW
RF Operating Voltage, maximum (vrms)	707 V

VSWR/Return Loss

Frequency Band	VSWR	Return Loss (dB)
0–3000 MHz	1.046	32.96
3000–6000 MHz	1.18	22

Mechanical Specifications

Connector Retention Tensile Force	330 N 74.187 lbf
Connector Retention Torque	0.56 N-m 4.956 in lb
Coupling Nut Proof Torque	1.7 N-m 15.046 in lb
Coupling Nut Proof Torque Method	IEC 61169-16:9.3.6
Coupling Nut Retention Force	450 N 101.164 lbf
Coupling Nut Retention Force Method	IEC 61169-16:9.3.11
Interface Durability	500 cycles
Interface Durability Method	IEC 61169-16:9.5
Mechanical Shock Test Method	IEC 60068-2-27

Environmental Specifications

Operating Temperature	-40 °C to +85 °C (-40 °F to +185 °F)
Storage Temperature	-65 °C to +125 °C (-85 °F to +257 °F)
Attenuation, Ambient Temperature	20 °C 68 °F
Average Power, Ambient Temperature	40 °C 104 °F

400BPNM-C

Average Power, Inner Conductor Temperature	100 °C 212 °F
Climatic Sequence Test Method	IEC 60068-1
Corrosion Test Method	IEC 60068-2-11
Damp Heat Steady State Test Method	IEC 60068-2-3
Immersion Depth	1 m
Immersion Test Mating	Mated
Immersion Test Method	IEC 60529:2001, IP68
Thermal Shock Test Method	IEC 60068-2-14
Vibration Test Method	IEC 60068-2-6

Packaging and Weights

Weight, net	37.55 g 0.083 lb
--------------------	--------------------

Regulatory Compliance/Certifications

Agency	Classification
CHINA-ROHS	Below maximum concentration value
ISO 9001:2015	Designed, manufactured and/or distributed under this quality management system
REACH-SVHC	Compliant as per SVHC revision on www.andrew.com/ProductCompliance
ROHS	Compliant
UK-ROHS	Compliant



* Footnotes

Insertion Loss, typical	0.05√freq (GHz) (not applicable for elliptical waveguide)
Immersion Depth	Immersion at specified depth for 24 hours

CNT-400-FR



CNT-400-FR, CNT® 50 Ohm Braided Coaxial Cable, black non-halogenated, fire retardant polyolefin jacket, Dca s2 d2 Compliant

Product Classification

Product Type	Braided coaxial cable
Product Brand	CNT®
Product Series	CNT-400

General Specifications

Braid Coverage	90 %
Cable Type	CNT-400
Jacket Color	Black

Dimensions

Diameter Over Dielectric	7.24 mm 0.285 in
Diameter Over Jacket	10.29 mm 0.405 in
Diameter Over Tape	7.391 mm 0.291 in
Inner Conductor OD	2.74 mm 0.108 in
Outer Conductor OD	8.08 mm 0.318 in
Nominal Size	0.400 in

Electrical Specifications

Cable Impedance	50 ohm
Capacitance	78 pF/m 23.774 pF/ft
dc Resistance, Inner Conductor	4.49 ohms/km 1.369 ohms/kft
dc Resistance, Outer Conductor	5.61 ohms/km 1.71 ohms/kft
dc Test Voltage	2500 V
Jacket Spark Test Voltage (rms)	4000 V
Maximum Frequency	16.2 GHz
Operating Frequency Band	30 – 6000 MHz
Peak Power	16 kW

CNT-400-FR

Shielding Effectiveness 90 dB

Velocity 85 %

Attenuation

Frequency (MHz)	Attenuation (dB/100 m)	Attenuation (dB/100 ft)
30.0	2.49	0.76
50.0	3.18	0.97
150.0	4.92	1.5
220.0	6.23	1.9
450.0	8.86	2.7
900.0	12.8	3.9
1500.0	16.7	5.1
1800.0	18.4	5.6
2000.0	19.4	5.9
2400.0	21.65	6.6
2500.0	22	6.7
3000.0	24.6	7.5
4000.0	28.87	8.8
4500.0	30.84	9.4
5000.0	32.81	10
5200.0	33.46	10.2
5500.0	34.78	10.6
5800.0	35.76	10.9
6000.0	36.42	11.1

Material Specifications

Braid Material	Tinned copper
Dielectric Material	Foam PE
Jacket Material	Non-halogenated, fire retardant polyolefin
Inner Conductor Material	Copper-clad aluminum wire
Shield Tape Material	Aluminum

Mechanical Specifications

Minimum Bend Radius, single Bend	25.4 mm 1 in
Tensile Strength	73 kg 160.937 lb

CNT-400-FR

Bending Moment	0.7 N-m 6.196 in lb
Flat Plate Crush Strength	0.7 kg/mm 39.198 lb/in

Environmental Specifications

Installation temperature	-40 °C to +60 °C (-40 °F to +140 °F)
Operating Temperature	-40 °C to +60 °C (-40 °F to +140 °F)
Storage Temperature	-40 °C to +60 °C (-40 °F to +140 °F)
EN50575 CPR Cable EuroClass Fire Performance	Dca
EN50575 CPR Cable EuroClass Smoke Rating	s2
EN50575 CPR Cable EuroClass Droplets Rating	d2
Fire Retardancy Test Method	UL VW1/CATVX
Smoke Index Test Method	IEC 61034
Toxicity Index Test Method	IEC 60754-2

Packaging and Weights

Cable weight	0.07 kg/m 0.047 lb/ft
Packaging Type	Reel

Regulatory Compliance/Certifications

Agency	Classification
CENELEC	EN 50575 compliant, Declaration of Performance (DoP) available
CHINA-ROHS	Below maximum concentration value
ISO 9001:2015	Designed, manufactured and/or distributed under this quality management system
REACH-SVHC	Compliant as per SVHC revision on www.andrew.com/ProductCompliance
ROHS	Compliant
UK-ROHS	Compliant

